



Product catalog

Laser cutting and bending technology

Smart and innovative cutting and bending solutions



ACCURL's Smart New Factory boasts a design capacity area of 61,362 square meters, a green area of 3,115 square meters, and an office area of 3,198 square meters. It is located near Nanjing, in the east of China. Several key modules were integrated into the construction of the new factory: photovoltaic energy, temperature-controlled and dust-free workshops, robotic intelligent welding, lean production management, automated production lines, digital manufacturing workshops, MES manufacturing execution systems, and intelligent logistics and warehousing systems.

Accurl Europe

The value of a choice

Since its foundation in 1988, ACCURL has stood for technological ambition, continuous innovation, and the determination to shape the future of metal processing. What began as a visionary family-owned company in China has grown into one of Asia's pioneering manufacturers of high-quality CNC systems — specializing in CNC press brakes, CNC shears, and state-of-the-art laser cutting machines.

Over the decades, ACCURL has invested heavily in research, development, and advanced manufacturing capabilities. By integrating cutting-edge technologies from Germany, Japan, and Italy, we have created tailor-made automated cutting and bending systems that combine precision, performance, and reliability. This unique blend of global engineering expertise and family-driven values has fueled our sustained growth, enabling us to deliver more than 13,500 press brakes and 9,000 laser systems worldwide as of the end of 2023.

As a proud member of the international ACCURL Group, ACCURL Europe GmbH carries this spirit forward into the European market. Headquartered in Bavaria, southern Germany, we provide certified specialist dealers across Europe with advanced ACCURL technology, in-depth expertise, and a full range of spare and wear parts. Together with our trusted partners, we ensure a consistently high level of service and support for every European customer — because technology is only as strong as the people who stand behind it.

This product catalog is more than a showcase of our portfolio. It is an invitation to experience ACCURL as a reliable partner for the next generation of manufacturing — innovative, forward-thinking, and dedicated to driving our customers' productivity and success.

Thank you for your trust. We look forward to shaping the future together.



Cameron Lee
Managing Director
Accurl Europe



Johannes Ried
Managing Director
Accurl Europe



Igor Mikulina
Managing Director
Accurl Europe

Table of contents

X-Series laser cutting systems

High-performance systems for 2D and 3D sheet metal processing

4

SMART Cube X

Laser cutting in a compact space

6

SmartLINE X

Efficient 2D laser cutting

8

MasterLINE X

Laser cutting at the highest level

10

SMART Giant X

Laser cutting in XXL format

12

Innovative tube lasers

TubeLINE: Efficient laser cutting of pipes, profiles and beams

14

TubeLINE A

Professional introduction to 2D laser cutting

16

TubeLINE BK

Flexible 2D/3D processing with fully automatable processes

18

TubeLINE D

Powerful 2D/3D processing for especially large dimensions

20

Efficient press brakes

The right solution for every bending task

22

SMART

Ideal entry-level press brake

24

eB ULTRA

Unique technologies for process-reliable precision

26

EuroMaster

The universal high-end press brake

28

GeniusPlus

The robust and versatile bending solution

30

X-Series Laser cutting systems

High-performance systems for 2D and 3D sheet metal processing

The X-Series fiber laser cutting systems from ACCURL Europe are powerful yet cost-effective systems for high-quality 2D and 3D laser cutting. These series owe their high reliability and process stability to the use of consistently top-quality brand-name components. At the same time, the highly attractive pricing, with comparatively manageable investment and operating costs, enables a rapid return on investment.

Result of intensive development

Whether 2D, 3D, compact or XXL: The X-Series combines the highest precision, enormous speed and true digital intelligence in a modular system! The X-Series is the result of intensive development work and for the first time combines modular machine architecture, high laser power, maximum dynamics and end-to-end digitalization in a platform-based approach.

Both in development and in production, the highest quality standards were consistently applied: The steel frame is annealed at over 600 °C to relieve stress for example. This process prevents any deformation of the frame, even under heavy use for many years.



Control system: TWINCUT S80

The TWINCUT S80 CNC control system takes over the complete control of all cutting components and the associated peripherals. It is equipped as standard with a user-friendly HMI (Human Machine Interface), which can be conveniently controlled via a 21.5" touchscreen or an ergonomic hand-held operating device. The clear graphical user interface enables intuitive operation and quick familiarization for users. Alternatively, the MSE SmartControl system from the German manufacturer Eckelmann can also be used.



THERMACUT: Cutting head

For the X-Series the cutting heads of the EX-TRABEAM® series from Thermancut can be integrated. These cutting heads, developed in Germany, offer highly reliable, future-proof, and economical cutting performance. As such, the EX-TRABEAM® series also meets the requirements of tomorrow's manufacturing (Industry 4.0). The user-friendly cutting head ensures excellent cutting results, while the integrated sensors provide optimal monitoring of the machining process and protection for all optical components. Depending on configuration and requirements, the X-Series product line can alternatively be equipped with cutting heads from Bochu.

WITTENSTEIN alpha: Gears & racks

Highest precision, dynamics and above-average torque density – that's what the reliable gears in combination with high-quality racks from WITTENSTEIN alpha are known for.



BOSCH Rexroth: Linear guides

As a technology leader, BOSCH Rexroth has been setting milestones in the field of innovative linear guides for decades – when it comes to highly precise, process-reliable results: the absolute first choice!



High-performance laser sources

With IPG Photonics and Raycus, there are two strong and renowned laser source manufacturers to choose from, who can draw on a wealth of experience and an enormous R&D base and are known for maximum process reliability and innovative products.



X-Series SMART Cube X

Laser cutting in a compact space



The SMART Cube X fiber laser cutting system from ACCURL Europe is the ideal solution for compact laser cutting. It combines efficiency with minimal space requirements and enables the production of high-precision parts. The series is available in working areas from 1,000 x 2,000 mm up to 1,500 x 3,000 mm and can be equipped with laser sources with a power output of up to 12 kW.

The fiber laser cutting system also impresses with its attractive pricing and low maintenance and operating expenses. Its high reliability and process safety are the result of being equipped exclusively with premium brand-name components.

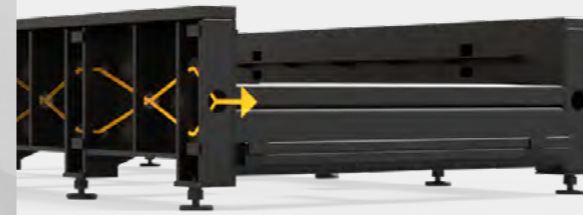
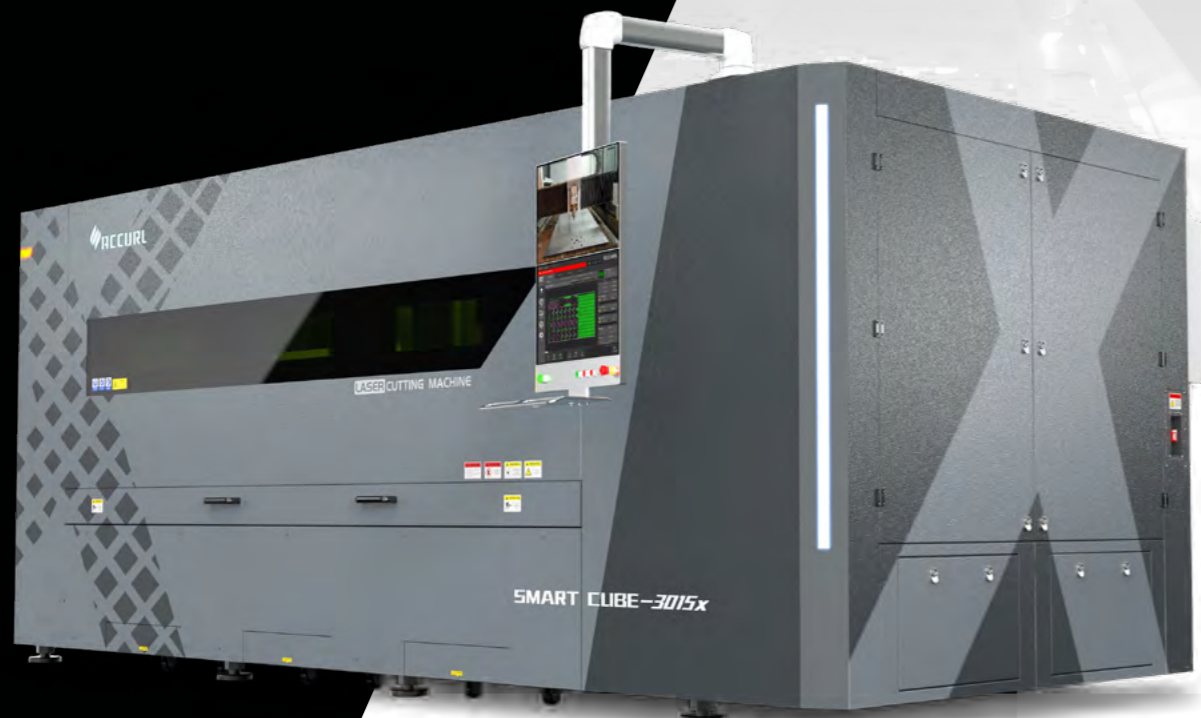

Highly dynamic machine gantry and solid, durable frame construction

The steel frame structure is annealed at over 600 °C to specifically relieve internal stresses. This ensures that dimensional stability is maintained even under long-term, high loads and effectively prevents distortion.

High accelerations are possible thanks to a weight-optimized and highly rigid design, as well as the low center of gravity.

High-performance laser sources

More laser, more beam intensity, more power: The SMART Cube X offers a choice of laser sources with a power output of 2 to 12 kW. Users can thus achieve even faster cutting results or cut greater material thicknesses; moreover, they benefit from maximum productivity, efficiency, and low unit costs.

The necessary power is provided by laser sources from the renowned manufacturers IPG Photonics and Raycus. Both suppliers stand for highly reliable and innovative products, have extensive experience, and a strong R&D base.



High-quality components from renowned brand manufacturers

The system owes its high reliability and process safety to the use of consistently high-quality brand-name components. Here a brief excerpt:

- Cutting head: THERMACUT Ex-Trabeam® (Germany) / BOCHU BLT (China)
- Control system: MicroStep Europa MSE SmartControl (Germany) / TWINCUT S80 (China)
- Servo drives: Eckelmann (Germany) / Yaskawa (Japan)
- Gears & racks: WITTENSTEIN alpha (Germany)
- Linear guides: BOSCH Rexroth (Germany)
- Gas valve: HOERBIGER LasGARCompact (Germany)



Excellent cutting quality for different materials

The SMART Cube X impresses with high-quality components and delivers precise cutting results on a wide variety of parts. The sensor technology integrated into the cutting head ensures stable and consistently high process quality, even in continuous multi-shift operation.

The laser system is suitable for cutting materials including mild steel, stainless steel, aluminum, brass, and copper. Depending on the laser source and material used, material thicknesses of up to 25 mm are possible.



X-Series SmartLINE X

Efficient 2D laser cutting

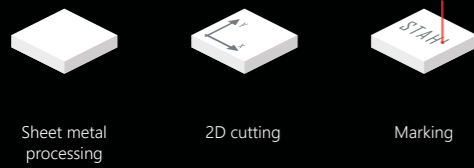

The SmartLINE X from ACCURL Europe is the high-performance choice for companies that require precise and economical 2D laser cutting with consistently high quality. With an acceleration of 2G and a transverse speed of up to 140,000 mm/min, the series combines dynamic motion profiles with stable process control – ideal for efficient cutting processes in daily operation. A significant advantage of the series is also its attractive price positioning. Laser sources from Raycus For the SmartLINE X, we rely on Raycus sources specifically developed for the European market: the high-performance CW series. With their dual safety circuitry and full CE and PLD compliance, they meet the highest standards for operational safety. The SmartLINE X enables an economical entry into professional laser processing – without compromising on quality, stability, or cutting performance.

The SmartLINE X is available in working areas from 3,000 x 1,500 mm to 6,000 x 2,500 mm and can be equipped with powerful fiber laser sources up to 30 kW. Reliable performance is ensured by a consistently robust design with proven brand-name components. The sturdy shuttle table construction enables efficient loading and unloading operations and contributes to short auxiliary times.

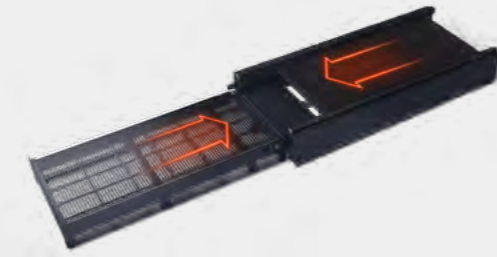

Modular and heavy-duty cutting gable

The SmartLINE X's shuttle table takes just a few seconds to extend or retract and can easily withstand even the heaviest loads: depending on the model, the structure can be loaded with up to 450 kg per m² without any issues.

The following table sizes are available: 3,000 x 1,500 mm, 4,000 x 2,000 mm, and 6,000 x 2,500 mm. The SmartLINE X table construction combines maximum stability, modular flexibility, and intelligent adaptability – for maximum precision even under extreme conditions: graphite plates protect the cutting bed from damage caused by the laser beam.

Laser sources from Raycus

For the SmartLINE X, we rely on Raycus sources specifically developed for the European market: the high-performance CW series. With their dual safety circuitry and full CE and PLD compliance, they meet the highest standards for operational safety.

The SmartLINE X enables an economical entry into professional laser processing – without compromising on quality, stability, or cutting performance. The sources for the SmartLINE X are available with a power output of 3 to 30 kW and guarantee first-class cutting quality, stability and efficiency. Integrated protection mechanisms against back reflections and real-time monitoring ensure maximum reliability in continuous operation.



High-quality components from renowned brand manufacturers

The system owes its high reliability and process safety to the use of consistently high-quality brand-name components. Here a brief excerpt:

- Cutting head: BOCHU BLT (China)
- Control system: TWINCUT S80 (China)
- Servo drives: Yaskawa (Japan) / INOVANCE (China)
- Gears & racks: WITTENSTEIN alpha (Germany)
- Linear guides: BOSCH Rexroth (Germany)
- Gas valve: HOERBIGER LasGARCompact (Germany)

Ultralight aluminum gantry with intelligent lubrication system

Ultra-high-speed laser cutting systems require extremely fast movements. However, if the rigidity of the cutting gantry is insufficient, vibrations occur that can noticeably impair cutting precision. ACCURL's ultra-lightweight aluminum crossbeam effectively remedies this by combining high dynamics with the necessary stability.

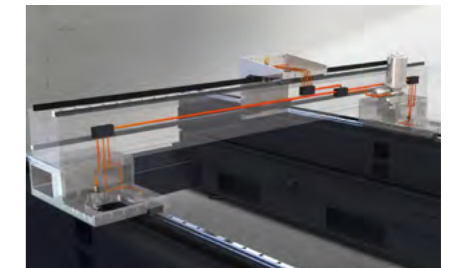

Excellent cutting quality for different materials

Thanks to its premium components, the SmartLINE X achieves outstanding cutting quality on a wide variety of materials. Special sensors integrated into the cutting head ensure consistently high quality even in multi-shift operation.

The laser system enables, among other things, the cutting of mild steel, stainless steel, aluminum, brass, and copper. Depending on the laser source and material, thicknesses of up to 50 mm can be processed.

X-Series MasterLINE X

Laser cutting at the highest level

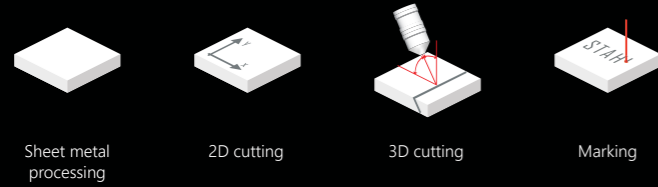

The MasterLINE X fiber laser cutting system from ACCURL Europe is an ultra-powerful system for highest quality 2D and 3D laser cutting. With an acceleration of 3G and a transverse speed of up to 180,000 mm/min, the system sets new standards in efficiency! The series is available in working areas from 3,000 x 1,500 mm to 8,000 x 2,500 mm and can be equipped with laser sources with a power output of up to 60 kW, making it ideally suited for processing both thin and thick materials.

The system owes its high reliability and process safety to being equipped with consistently high-quality brand components. The superior shuttle table design enables seamless loading and unloading at a consistent height, allowing for easy integration into automated material flow and handling processes.

HIGH POWER
Laser power up to 60 kW



Modular and heavy-duty cutting table

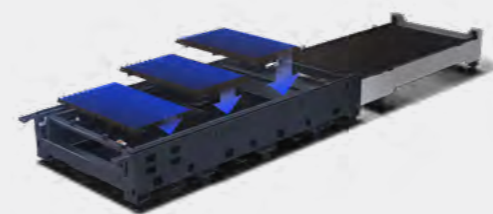

The shuttle table of the MasterLINE X only needs a few seconds to move in or out and easily withstands even the highest load capacities: depending on the configuration, the structure can be loaded with up to 550 kg per m² without any difficulty.

The following table sizes are available: 3,000 x 1,500 mm, 4,000 x 2,000 mm, 6,000 x 2,000 mm, 6,000 x 2,500 mm and 8,000 x 2,500 mm. The table construction of the MasterLINE X combines maximum stability, modular flexibility and intelligent adaptability – for maximum precision even under extreme conditions.

High Power: up to 60 kW laser power for maximum productivity

More laser, more beam intensity, more power: Laser sources with a power output of up to 60 kW are available for this series. Users can therefore achieve even faster cutting results or cut greater material thicknesses; moreover, they benefit from maximum productivity, efficiency, and low unit costs.

The necessary power is provided by laser sources from the renowned manufacturers IPG Photonics and Raycus. Both suppliers stand for highly reliable and innovative products, possess a wealth of experience, and have a strong R&D base.



High-quality components from renowned brand manufacturers

The system owes its high reliability and process safety to the use of consistently high-quality brand-name components. Here a brief excerpt:



- Cutting head: THERMACUT Ex-Trabeam® (Germany) / BOCHU BLT (China)
- Control system: MicroStep Europa MSE SmartControl (Germany) / TWINCUT S80 (China)
- Servo drives: Eckelmann (Germany) / Yaskawa (Japan)
- Gears & racks: WITTENSTEIN alpha (Germany)
- Linear guides: BOSCH Rexroth (Germany)
- Gas valve: HOERBIGER LasGARCompact (Germany)

Ultralight aluminum gantry with intelligent lubrication system

Ultra-high-speed laser cutting systems require extremely fast movements. However, if the rigidity of the cutting gantry is insufficient, vibrations occur that can noticeably impair cutting precision. ACCURL's ultra-lightweight aluminum crossbeam effectively remedies this by combining high dynamics with the necessary stability.

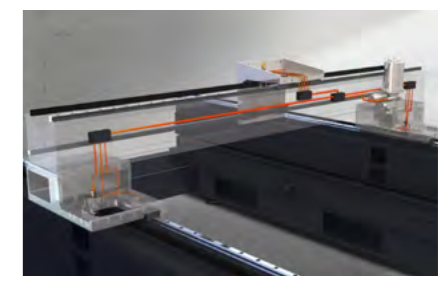

Laser rotator & automatic nozzle changer (optional)



ACCURL's Advanced Bevel Cutting Head enables perfect weld preparation: Using the beveling unit, the system produces weld-ready parts in a single step. Precise A, V, X, K, and Y bevels up to 45° can be produced quickly, stably, and with high precision. ACCURL's new auto nozzle changer system revolutionizes nozzle changing on laser cutting systems. Instead of time-consuming manual changing and calibration, the intelligent system handles everything automatically—quickly, precisely, and reliably.

Excellent cutting quality for different materials

Thanks to its superior components, the MasterLINE X achieves outstanding cutting quality on a wide variety of parts. Special sensors integrated into the cutting head ensure consistently high quality even in multi-shift operation.

The laser system enables, among other things, the cutting of mild steel, stainless steel, aluminum, brass, and copper. Depending on the laser source and material, thicknesses significantly exceeding 50 mm can also be processed.



X-Series SMART Giant X

Laser cutting in XXL format

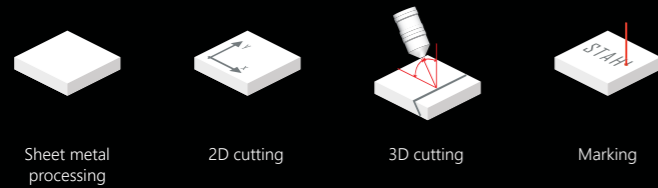

The SMART Giant X is the large-format fiber laser system for maximum efficiency and autonomy! Equipped with a 12–60 kW laser, the SMART Giant X enables precise cuts even in thicker materials with minimal operator effort. The modular design offers standard processing lengths from 6,100 mm to 15,100 mm with a standard working width of 3,100 mm, and can even be extended up to 42,100 mm if required. This allows the SMART Giant X to process particularly large sheet metal sheets, enabling optimized nesting with minimal material waste. Furthermore, simultaneous cutting and loading/unloading on separate table sections reduces downtime and ultimately increases productivity.



HIGH POWER
Laserleistung bis 60 kW

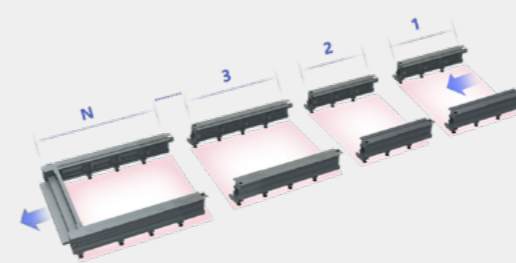

Modular and heavy-duty cutting table

The SMART Giant X sets new standards for large-format laser cutting systems and features a modular design. As standard, it can be configured with a working width of 3,100 mm and a working length of 6,100, 9,100, 12,100, or 15,100 mm. If required, a length of up to 42,900 mm can even be achieved. The table structure of the SMART Giant X can withstand loads of up to 750 kg/m², thus combining maximum stability, modular flexibility, and intelligent adaptability – for maximum precision even under extreme conditions.

High Power: up to 60 kW laser power for maximum productivity

More laser, more beam intensity, more power: Laser sources with a power output of up to 60 kW are available for this series. Users can therefore achieve even faster cutting results or cut greater material thicknesses; moreover, they benefit from maximum productivity, efficiency, and low unit costs.

The necessary power is provided by laser sources from the renowned manufacturers IPG Photonics and Raycus. Both suppliers stand for highly reliable and innovative products, possess a wealth of experience, and have a strong R&D base.

Laser power up to 60 kW

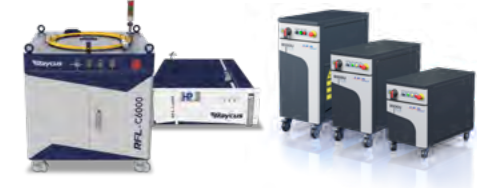

High-quality components from renowned brand manufacturers

The system owes its high reliability and process safety to the use of consistently high-quality brand-name components. Here a brief excerpt:

- Cutting head: THERMACUT Ex-Trabeam® (Germany) / BOCHU BLT (China)
- Control system: MicroStep Europa MSE SmartControl (Germany) / TWINCUT S80 (China)
- Servo drives: Eckelmann (Germany) / Yaskawa (Japan)
- Gears & racks: WITTENSTEIN alpha (Germany)
- Linear guides: BOSCH Rexroth (Germany)
- Gas valve: HOERBIGER LasGARCompact (Germany)

Laser rotator & automatic nozzle changer (optional)

ACCURL's Advanced Bevel Cutting Head enables perfect weld preparation: Using the beveling unit, the system produces weld-ready parts in a single step. Precise A, V, X, K, and Y bevels up to 45° can be produced quickly, stably, and with high precision. ACCURL's new auto nozzle changer system revolutionizes nozzle changing on laser cutting systems. Instead of time-consuming manual changing and calibration, the intelligent system handles everything automatically—quickly, precisely, and reliably

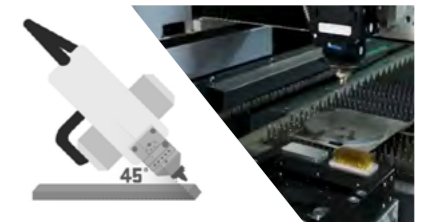

Safety concept: Protection at top speed!

For ultra-fast acceleration and parallel processes like loading and unloading, a conventional safety concept is insufficient. The SG-X safety system from ACCURL monitors the environment in real time and prevents collisions – for maximum safety and productivity.

Excellent cutting quality for different materials

Thanks to its premium components, the SMART Giant X achieves outstanding cutting quality on a wide variety of materials. Special sensors integrated into the cutting head ensure consistently high quality even during multi-shift operation.

The laser system enables, among other things, the cutting of mild steel, stainless steel, aluminum, brass, and copper. Depending on the laser source and material, thicknesses significantly exceeding 50 mm can also be processed.



Innovative tube laser

TubeLINE: Efficient laser cutting of pipes, profiles and beams

With TubeLINE ACCURL Europe offers cutting-edge technology for pipe cutting.

The TubeLINE is a compact and efficient solution for cutting pipes, profiles, and beams, featuring numerous advanced technologies for optimal process results. This highly dynamic machine is perfectly suited for producing high-precision parts at high cutting speeds – enabling the creation of the finest contours and openings, as well as precise bevel cuts.

The system offers versatile options for processing a wide variety of material geometries. Top-quality components and sophisticated, first-class technology ensure maximum process reliability. The extremely user-friendly design of the system facilitates rapid adaptation of production to changing material types, thicknesses, and geometries.

Software and control of Bochu

Thanks to high-quality components and a clever machine design, the TubeLINE simplifies many aspects of laser tube cutting. Processes. A highly precise, ultra-fast and extremely innovative EtherCAT CNC controller from Bochu ensures the best performance of the overall system.

In combination with the user-friendly yet highly functional TubePro® software, users thus work with one of the most advanced solutions for pipe and profile processing.

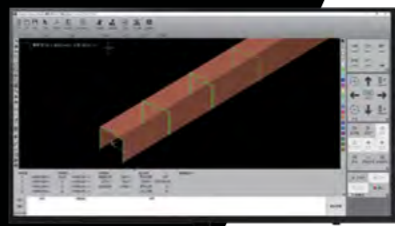

Robust mechanical engineering for excellent process reliability

For the TubeLINE series, ACCURL, among others, developed robust, pneumatically operated chucks. These can precisely execute even highly dynamic movements and are versatile in terms of the geometries to be clamped: Square pipes, round pipes, elliptical pipes, flat pipes and triangular geometries, as well as I-beams and other material shapes, can be clamped and processed without any difficulty.

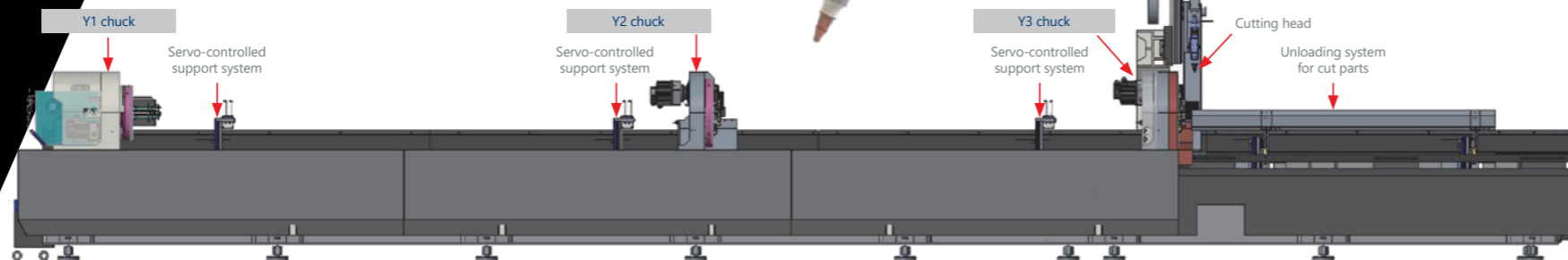

Schematic diagram of the TubLINE BK machine: A 3-chuck tube laser cutting system with three chucks that simultaneously clamp, guide, and transfer the tube between them during the process. This ensures that the material remains securely clamped even with long or thin tubes and can be moved precisely while the laser cuts.

The machine design minimizes pipe vibrations and ensures very high accuracy, even with complex geometries. Depending on the machine type, the clamping systems of the TubeLINE series can be used to cut pipes with diameters from 10 mm to 510 mm.

3D cutting head for Bevel cuts up to 45°

Depending on the model, the TubeLINE can be equipped with a 3D cutting head for bevel cuts and miter cuts from -45° to +45°. Weld preparation can thus be carried out more precisely and efficiently than with a manual method. Depending on the part geometry, simple V- and X-welds as well as more complex V- or K-welds with micro joints can be cut. Programming is incredibly easy thanks to the intuitive software solution. A non-contact distance control ensures consistent nozzle distances to the cutting material, resulting in optimal cutting quality.

BOCI® cutting heads offer excellent performance with stable cutting, easy installation and setup, and are equipped for high laser power up to 30 kW and more.

The top-of-the-line version is characterized by innovative features. BOCI® cutting heads in 3D cutting through a variety of useful features are included:

- Implementation of bevel cuts from -45° to +45° for positive and negative chamfer angles
- Autofocus control
- Magnetic collision protection
- Upper and lower protective glass to protect collimation and focusing optics
- Service-friendly access to the lower protective glass thanks to a drawer-like design
- Cutting distance can be adjusted from 0.1 mm
- Fast and highly dynamic capacitive Distance regulation for even better Cutting results



The TubeLINE can be equipped with a 3D head to perform bevel cuts up to 45°. This makes it possible to produce corner joints extremely precisely and efficiently with optimal material utilization.



Thanks to their high precision, ACCURL Europe's tube cutting solutions also enable, for example, the uncomplicated joining of sheet metal parts and tubes (the image shows, as an example, the simple production of plug-in flange connections).



Replace the time-consuming fixing parts for the welding by means of plugs, dovetail and bayonet connectors!

ACCURL Europe's cutting solutions make it easy to connect pipes with fittings – a perfect option for manufacturing load-bearing pipe structures.

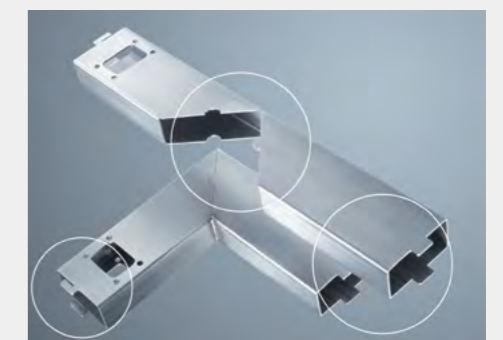

Laser tube cutting solutions of the TubeLINE series, for example, also allow for the extremely efficient production of bent joints and positioning aids.

TubeLINE A

Professional introduction to 2D laser cutting

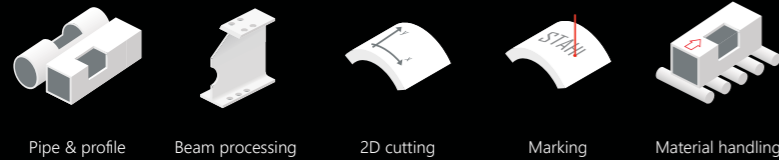

The TubeLINE A offers the ideal entry into modern 2D processing of pipes, profiles and beams. The machine combines a compact design with precise laser technology and enables reliable, efficient processing of a wide range of shapes. As standard, it is equipped with two chucks that ensure high-precision manufacturing even for particularly long parts. The high-quality components guarantee stable results in daily operation, while the user-oriented interface allows quick adjustments to different material and shape requirements – providing a solid foundation for a professional and practice-oriented start in laser-assisted pipe processing.

Further highlights of the TubeLINE A include:

- Supportive pipe rests to prevent sagging of pipes or profiles
- Servo-controlled support system for optimal alignment of the material to the chuck
- Unloading area optionally extendable

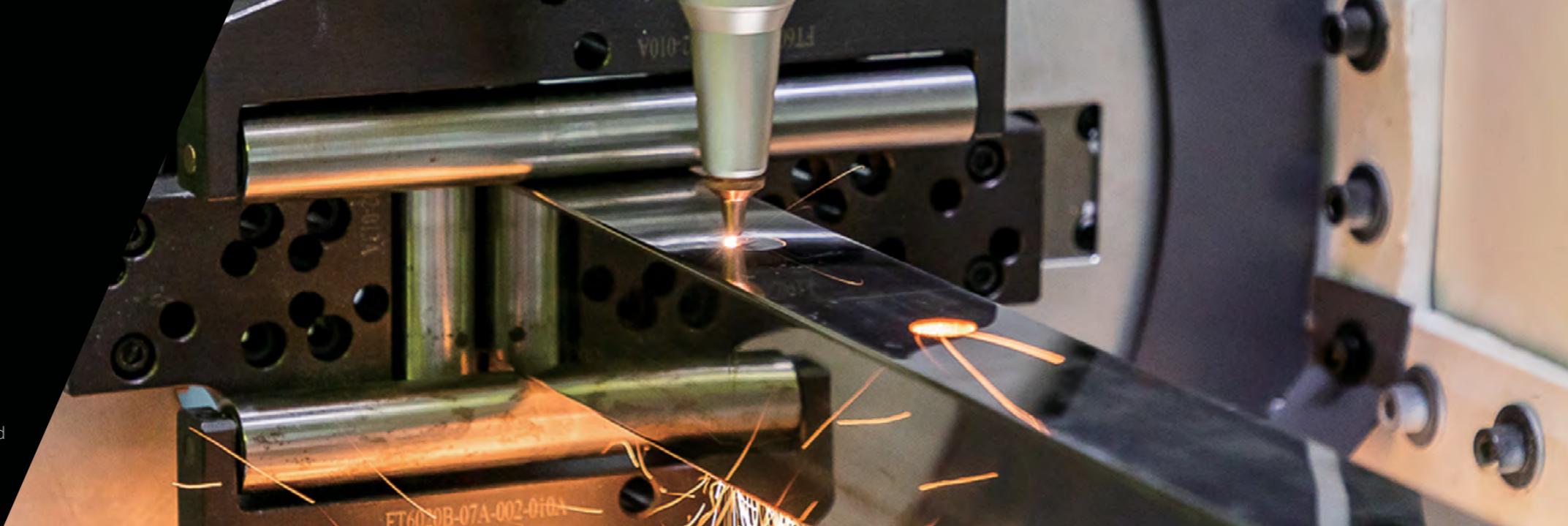

Automation option for the TubeLINE A:

Semi-automatic loading system



The TubeLINE A series can be optionally equipped with the semi-automatic SAT loading system. In this setup, pipes and profiles are placed individually and transported via conveyor belts to the automated clamping unit before the cutting process begins.

The system can be configured for a wide range of requirements:

- Laser sources with power levels from 2 kW to 6 kW
- Processing range for pipes: 8 to 360 mm in diameter
- Processing range for profiles: 8 to 360 mm edge length
- Precise processing of materials up to 6,000 mm in length



TubeLINE BK

Flexible 2D/3D processing with fully automatable processes

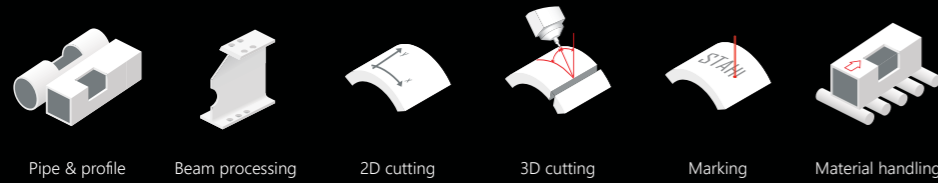

The TubeLINE BK is a compact and efficient solution for cutting pipes, profiles and beams, equipped with numerous advanced technologies to ensure optimal process results. The system offers versatile capabilities for processing a wide range of material geometries. Even in its standard configuration, it features three chucks that ensure exceptionally reliable and highly precise manufacturing, even for particularly long parts. Premium-grade components combined with sophisticated, first-class engineering guarantee maximum process reliability. The highly user-friendly system design enables quick adjustments to varying material types, thicknesses and geometries.

- Laser sources with power levels from 3 kW to 8 kW
- Processing range for pipes: 12 to 280 mm in diameter
- Processing range for profiles: 12 to 200 mm edge length
- Precise processing of materials up to 9,100 mm in length
- Supportive pipe rests to prevent sagging of pipes or profiles
- Servo-controlled support system for optimal alignment of the material with the chuck
- Unloading area optionally extendable
- Zero-cut function for maximum material utilization through scrap-free pipe cutting



Servo-controlled support system



On the loading side, a servo-controlled support system – easily adjustable for various material geometries – ensures the precise alignment of the material with the chuck, into which it is then automatically clamped.



Supportive pipe rests

The equipment includes, among other features, supportive pipe rests on the unloading side, which prevent pipes or profiles from sagging. During pipe or profile rotation in the cutting process, these rests automatically adjust in height as needed.

Automation options for the TubeLINE BK:

Fully automatic charging system

The optional ATL loading system for the TubeLINE BK series operates fully automatically and requires no mechanical intervention – even when switching to a new production batch.



Users can load materials of all defined standard sizes and start series production immediately with minimal manual effort. Round tubes, square and rectangular profiles, are simply inserted and then transported to the waiting area for length measurement and determination of the cutting sequence.

FEATURES:

- The system is easy to load, with bundles
- Ideal solution for series production or the automated processing of larger batch sizes!
- Loading size range: Ø pipe 25 – 150 mm, edge length profile 25 – 150 mm
- Fast charging times: < 60 seconds on the first charge, < 20 seconds in case of repetition



Semi-automatic loading system

As an alternative to the fully automatic loading system ATL, a semi-automatic loading system SAT is also optionally available for the TubeLINE BK series: Here, individual tubes and profiles are placed on the system and transported via conveyor belts for automated clamping.

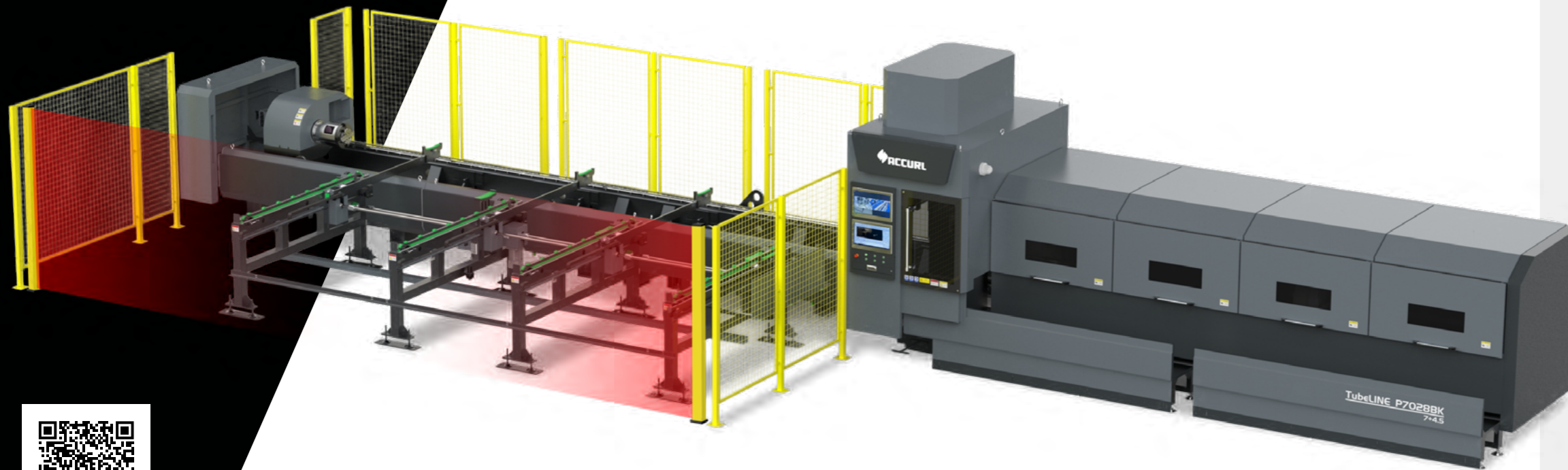

TubeLINE D

Powerful 2D/3D processing for especially large dimensions

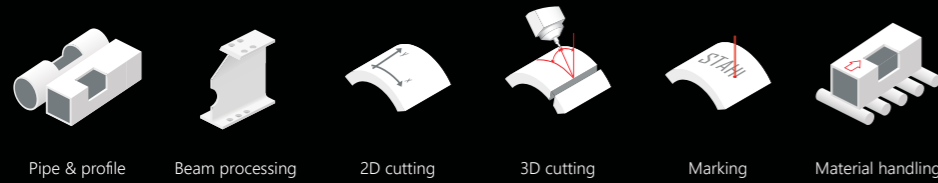

Loading and unloading on the TubeLINE D is performed from the front. The servo-driven and perfectly synchronized material-handling systems of this semi-automatic pipe and profile laser provide the basis for meeting virtually all production requirements – from single-part manufacturing to large-batch production. Even in the standard configuration, the system is equipped with three chucks that ensure exceptionally reliable and highly precise fabrication of even particularly long parts. Also included as standard is an innovative 3D cutting head from the Asian technology leader Bochu, enabling the machine to handle a wide range of applications in laser cutting of various pipe, profile and beam geometries.

Further highlights of the TubeLINE D:

- Zero-cut function for maximum material utilization through scrap-free pipe cutting
- Automated loading and unloading system



The system can be configured for a wide range of requirements:

- Laser sources with power levels from 6 kW to 20 kW
- Processing range for pipes: 40 to 580 mm in diameter
- Processing range for profiles: 40 to 500 mm edge length
- Precise processing of materials up to 12,200 mm in length

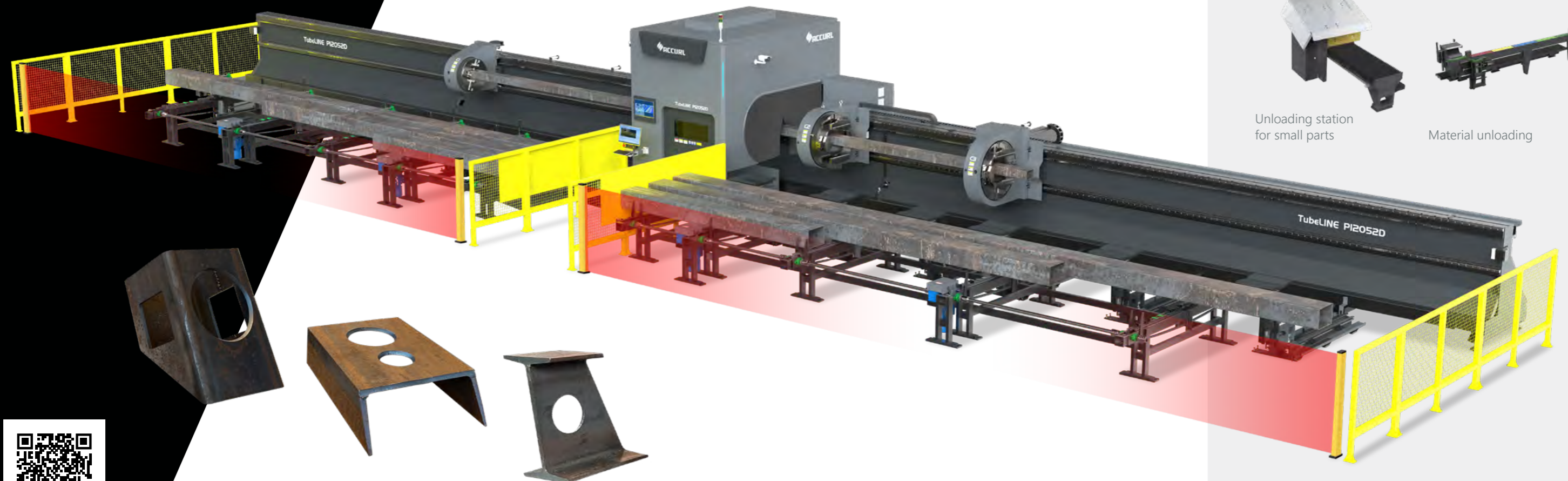

Square profiles, U-profiles and H-beams can be cut highly efficiently and with ease using the TubeLINE D series.



Efficient press brakes

The right solution for every bending task

The press brakes from ACCURL Europe combine cost-efficient investment with precise and reliable performance.

Quality: Top-level mechanical engineering

Already during the design phase of the press brakes, ACCURL relies on the most advanced 3D CAD modeling techniques, including analysis tools such as Computer-Aided Engineering (CAE) software programs. Stresses and deformations that occur during the bending process – due to the sometimes immense forces acting on the machine structure – to be virtually simulated and constructively reduced to an absolute minimum. And in operation ACCURL Europe's press brakes are characterized by exceptionally high process reliability: only the highest quality components from well-known brand manufacturers such as Siemens, Heidenhain, and HAWE Hydraulik are installed.

Sustainability & Efficiency: Innovative press drives

For the press brakes from ACCURL Europe only highly efficient drive systems are offered: In the EuroMaster series, for example, the electro-hydraulic ePrAX® control press drive from HAWE Hydraulik is included as standard. Compared to conventional hydraulic press brakes, it is extremely efficient (energy savings of up to 75%), exceptionally fast (cycle time reduction of up to 35%), ultra-precise (positioning accuracy of up to 5 µm!), very quiet, and highly environmentally friendly (up to 90% less oil!). In the fully electric eB ULTRA series, all of these advantages over a purely hydraulic press drive are even more pronounced. The result is a significant reduction in time, resource consumption, and waste – ultimately saving real money!

Precision: Constant angle over the entire bending length

One of the unavoidable phenomena in press brakes is structural deformation. In particular the upper beam tends to deflect in the middle when processing medium and higher material thicknesses, resulting in a larger gap between punch and die in this area. Without compensation of this effect, the bending result in the center does not match the desired angle outcome. The ultra-precise drive systems installed by ACCURL, in combination with the CNC-controlled crowning systems, compensate for the structural deformation during the bending process, ensuring that the desired bending angle is consistently achieved along the entire length of your press brake. In press brakes from ACCURL, these precision systems are already included as standard.

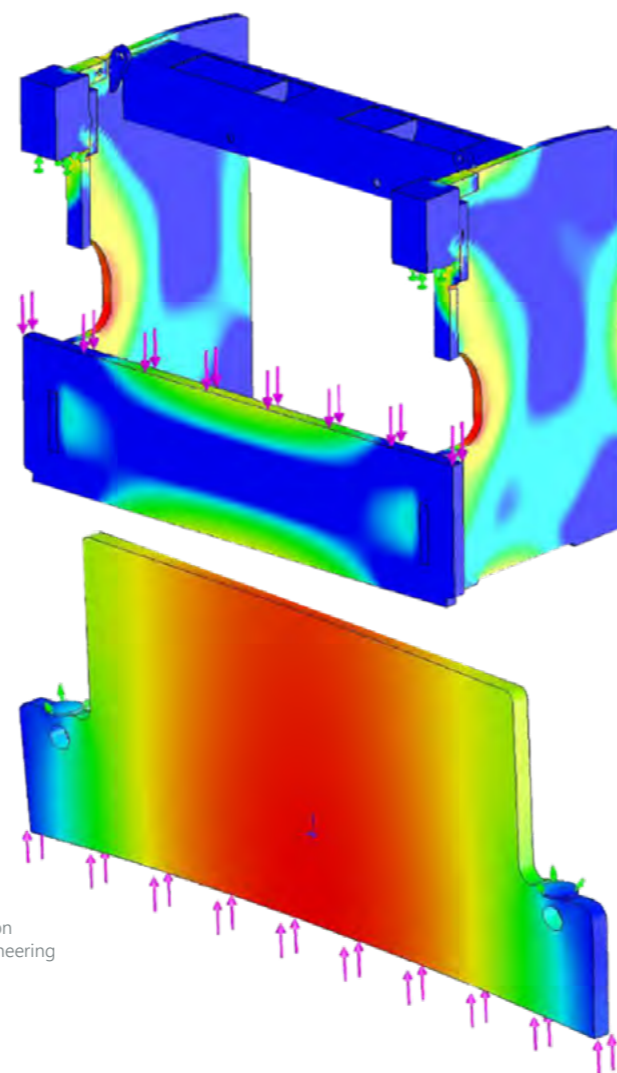

Analysis result based on Computer-Aided Engineering



Electro-hydraulic press drive ePrAX® control

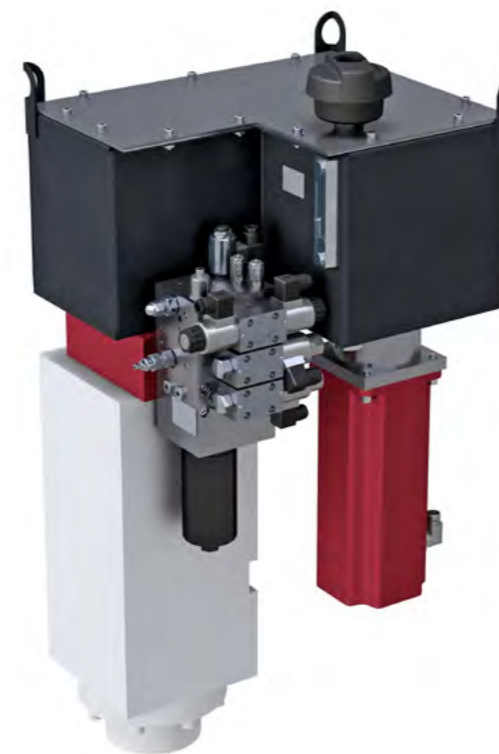

Angle measuring systems

Precise angle measurements and corrections are essential for precision sheet-metal fabrication, particularly in bending. ACCURL iMeasure® is a fully automatic, laser-assisted bending-angle measurement and correction system for CNC press brakes (see upper image). Regardless of the bending strength or thickness of the material being processed, iMeasure enables highly accurate determination of the bending angle with exceptional precision. As an alternative – particularly for machines with shorter bending lengths – an angle-measurement system integrated into the safety system is available: IRIS Plus is highly economical to purchase and provides real-time angle correction (see lower image).

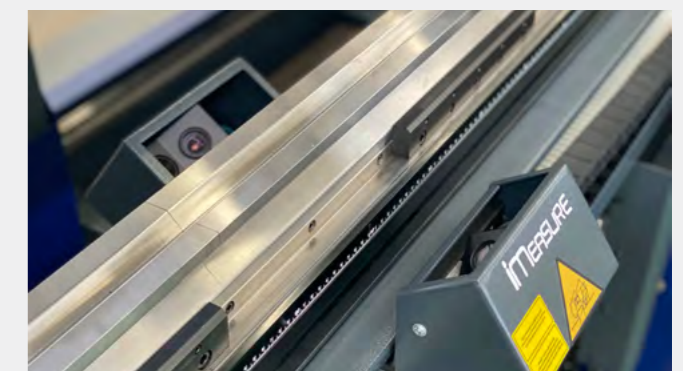

SMART

Ideal entry-level press brake

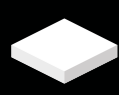

Plates



Material handling automated

The SMART series from ACCURL Europe combines cost-effectiveness with a wide range of functions: a CNC press brake with numerous equipment options. Even in its standard configuration, the series features sliding support arms as well as ACCURL® quality tool clamps, type PROMECAM. Additionally, material handling to and from the machine can be automated using a robot.



Press force: Wide range covered

Depending on requirements, the SMART series can be equipped with a press force of 400 to 6,000 kN. Based on the individual configuration, the press brake offers a working range of 1,500 to 6,000 mm in length.

State-of-the-art control technology from quality manufacturer Delem

In its standard configuration, the SMART series features state-of-the-art CNC control technology from Delem. The latest DA-Touch generation impresses with its ease of operation and highly efficient programming – ideal for productive work. Alternatively, control systems from ESA or Cybelec can be integrated upon request to precisely meet specific customer requirements.

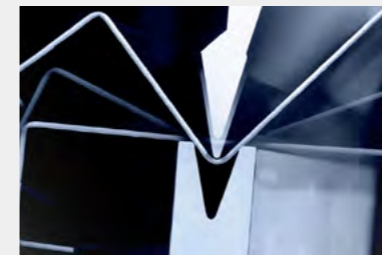

Precision: Constant bending angle across the entire length

The high-precision electro-hydraulic system EVO-GO® works in conjunction with the CNC-controlled ACCURL Pro® crowning system and compensates for structural deformations that occur during the bending process. This ensures that the desired bending angle is achieved reliably and uniformly across the entire bending length. Both technologies are already integrated as standard in the SMART series.

Flexibility: Backgauge with up to 4 axes

In its standard configuration, the backgauge of this series features two CNC-controlled axes (X and R). The stop fingers are automatically positioned via the CNC program. The robust design ensures maximum repeatability and precise axis movements. For greater flexibility in programming and part processing, the series can be optionally expanded with two additional axes (Z1 and Z2).



Quality tool clamping system

Even in the standard configurations, the press brakes are equipped with high-quality ACCURL® clamping systems. The upper tool clamp is compatible with PROMECAM tools as standard, while the lower tool clamp is compatible with both PROMECAM and WILA tools. Manual, pneumatic, or hydraulic clamping solutions are available for both clamps – optionally using PROMECAM or WILA products.

Sustainability & Efficiency: Electro-hydraulic press drive

The series is equipped with an innovative electro-hydraulic system that intelligently combines the strengths of both drive technologies: Unlike a purely electric drive, it is powerful and durable thanks to hydraulics, but due to its compact design, it operates cleanly and without leakage, without external oil lines.



eB ULTRA

Unique technologies for process-reliable precision



Plates



Material handling automated

The 100% electric press brake from the eB ULTRA series is highly efficient, extremely precise, and exceptionally fast, thanks in part to its innovative drive system. From the very beginning of the development process, our engineers rely consistently on state-of-the-art 3D CAD software and FEM analysis tools, ensuring maximum structural stability. With its innovative drive system, the eB ULTRA minimizes cycle times and energy consumption, making it exceptionally economical in operation.

The eB ULTRA series from ACCURL Europe is cost-efficient to purchase and delivers accurate and reliable performance. Even in its standard configuration, the series is equipped with sliding support arms and pneumatically operated ACCURL Air® quality tool clamps, type PROMECAM. Alternatively, the series can be equipped with tool clamping systems and crowning systems from the renowned manufacturer WILA.

In addition, material handling to and from the machine can be automated in combination with a robot.



Presskraft: Exakt auf Ihre Bedürfnisse abgestimmt

The eB ULTRA series can be equipped with a press force of 250 to 1,250 kN, depending on requirements. Based on the individual configuration, the press brake offers a working range of 800 to 3,050 mm in length.

State-of-the-art control systems from Delem

The eB ULTRA series comes standard with state-of-the-art CNC control technology from the renowned manufacturer Delem: cutting-edge technology that allows users to get the most out of their press brake and is simple and intuitive to operate. The new generation of DA-Touch controls offers a very high degree of efficiency in programming, operating, and controlling press brakes. Alternatively, controls from the manufacturers ESA or Cybelec are available.



Ultra-precise: ACCURL ULTRA® crowning system

The ultra-precise, all-electric drive system of the eB ULTRA series, in combination with the standard CNC-controlled crowning system ACCURL ULTRA®, compensates for deformation of the structure during the bending process and ensures that the desired bending angle is consistently achieved over the entire length of your press brake.

High flexibility thanks to the 4-axis backgauge as standard

The standard backgauge on the eB ULTRA series already includes four CNC-controlled axes: X, R, Z1, and Z2. This ensures a very high degree of flexibility in programming and part production right from the start. The backgauge fingers are positioned automatically by the CNC program. Additional axes (X1, X2) can also be configured as an option.



Practical: Integrated tool storage

Particularly practical: A tool storage area is already integrated into the side panel of your new eB ULTRA press brake, allowing you to always have the most important upper and lower tools quickly at hand when needed.

All-electric drive: Efficient, fast and precise

The agile electromechanical drive system – requiring hardly any start-up time – in combination with the highly dynamic IRIS safety equipment from lazersafe® ensures a corresponding reduction in cycle time compared to purely hydraulic press drives.



EuroMaster

The universal high-end press brake



Plates



Material handling automated

The EuroMaster series stands for top quality and maximum reliability – throughout the entire lifetime of the machine! Already during the development of this series, our engineers consistently rely on the latest generation of 3D CAD software and FEM analysis tools, thus achieving maximum structural stability.

The EuroMaster series from ACCURL Europe is cost-efficient to purchase and operates precisely and reliably. Even in the standard version the series includes sliding support arms and ACCURL® tool clamps, type PROME-CAM. Alternatively, the EuroMaster can be equipped with tool clamps and crowning systems from the renowned manufacturer WILA.

In addition, the material handling to and from the EuroMaster system can be automated in combination with a robot.

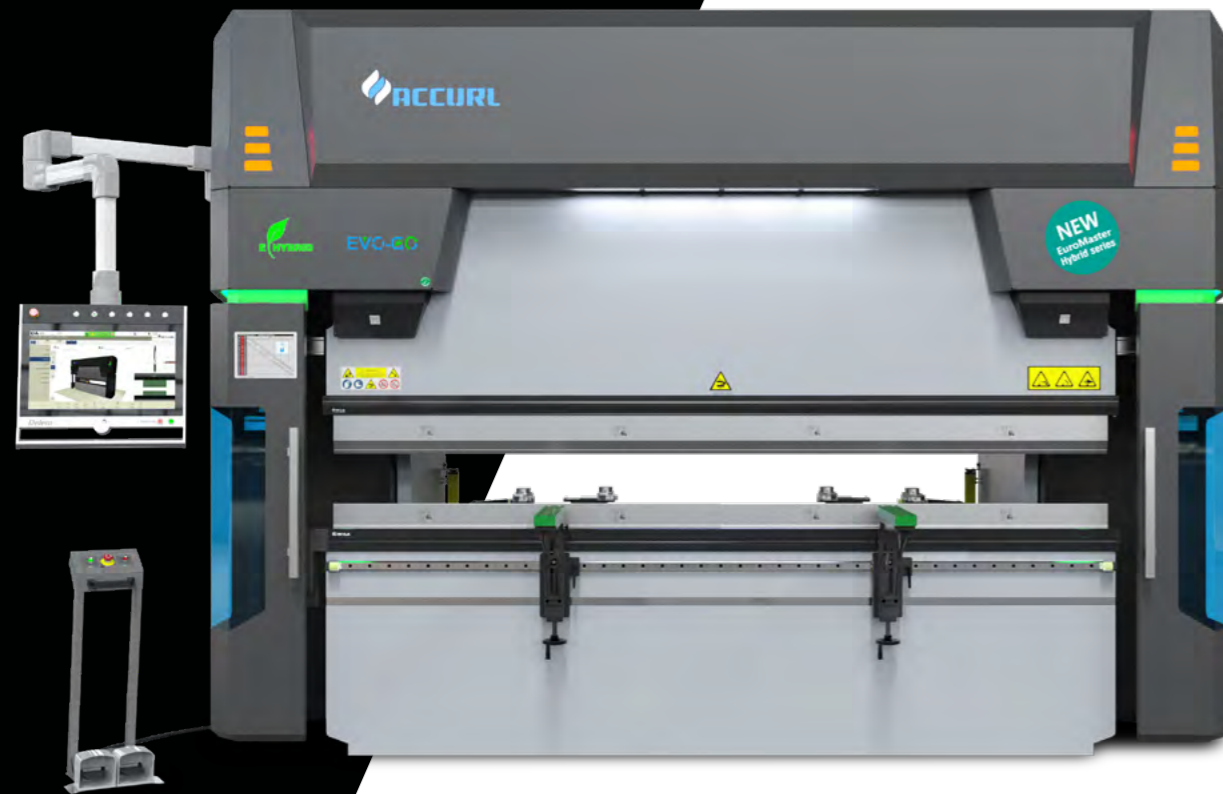

Press force: Precisely tailored to your needs

The EuroMaster series can be equipped with a press force of 800 to 4,000 kN, depending on requirements. Based on the individual configuration, the press brake offers a working range of 2,550 to 4,200 mm in length.

State-of-the-art control systems from Delem

The EuroMaster series comes standard with state-of-the-art CNC control technology from the renowned manufacturer Delem: cutting-edge technology that allows users to get the most out of their press brake and is easy and intuitive to operate. The new generation of DA-Touch controls offers a very high degree of efficiency in programming, operating, and controlling press brakes. Alternatively, controllers from the manufacturers ESA or Cybelec are available.

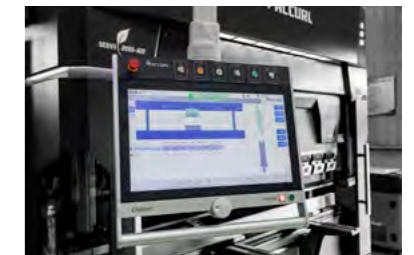

Maximum precision: ACCURL ULTRA® crowning system

The ultra-precise electro-hydraulic ePrAX® control system from HAWE Hydraulik, in combination with the CNC-controlled ACCURL ULTRA® crowning system, compensates for structural deformation during the bending process and ensures that the desired bending angle is consistently achieved across the entire length of your press brake. In the EuroMaster series, both precision systems are already included as standard.

High flexibility thanks to the 4-axis backgauge as standard

The standard EuroMaster backgauge already includes four CNC-controlled axes: X, R, Z1, and Z2. This ensures a very high degree of flexibility in programming and part production right from the start. Additional axes (X1 and X2) can, of course, be configured as options.



Practical: Integrated tool storage (optional)

Particularly practical: A tool storage area can be integrated into the side panel of the new EuroMaster press brake, allowing the most important upper and lower tools to be quickly accessible whenever needed.

Efficient, fast and sustainable: ePrAX control® servo drive

The EuroMaster comes standard with the innovative electro-hydraulic ePrAX® control system from HAWE Hydraulik. The agile drive system, in combination with the highly dynamic IRIS safety equipment from lasersafe®, delivers, among other things, a performance increase of up to 35% compared to purely hydraulic press drives, by significantly reducing cycle times.



GeniusPlus

The robust and versatile bending solution



The GeniusPlus series offers exceptional flexibility in its configuration and can be adapted to specific customer requirements. Its straightforward standard features make it a cost-effective and reliable entry-level model for a wide range of bending applications. Furthermore, this series is well-suited for applications requiring long bending lengths and high tonnage. With its ability to handle bending lengths from two to nine meters and bending forces of up to 1,250 tons as standard, it provides a robust solution for demanding bending requirements. The GeniusPlus series can also be configured as a tandem or tridem solution – for example, to bend particularly long sheets, such as those used for light poles or facade elements.

In addition, the material handling to and from the system can be automated in combination with a robot.

The GeniusPlus series represents the highest level of quality and reliability. It is characterized by its versatility, precision, and efficiency. The series was developed using state-of-the-art technologies – including advanced 3D CAD software and FEM analysis tools – to ensure maximum structural stability. With its high-quality construction, precise bending, and cutting-edge control technology, it is the ideal choice for companies seeking quality, reliability, and efficiency.



Press force: Precisely tailored to your needs

The GeniusPlus series can be equipped with a press force of 600 to 12,500 kN, depending on requirements. Based on the individual configuration, the press brake offers a working range of 2,000 to 9,000 mm in length.

State-of-the-art control systems from Delem

The GeniusPlus series comes standard with state-of-the-art CNC control technology from the renowned manufacturer Delem: cutting-edge technology that allows users to get the most out of their press brake and is easy and intuitive to operate. The new generation of DA-Touch controls offers a very high degree of efficiency in programming, operating, and controlling press brakes. Alternatively, controls from the manufacturers ESA or Cybelec are available.



Maximum precision: ACCURL ULTRA® crowning system

The ultra-precise electro-hydraulic system EVO-GO®, in combination with the CNC-controlled crowning system ACCURL ULTRA®, compensates for structural deformation during the bending process and ensures that the desired bending angle is consistently achieved across the entire length of your press brake. Both precision systems are already integrated as standard in the GeniusPlus series.

High flexibility: Backgauge with up to 6 axes

The standard GeniusPlus series backgauge includes two CNC-controlled axes: X and R. Its robust construction ensures very high repeatability and precision in axis positioning. Additional axes (Z1, Z2, X1, X2) are also available as options.

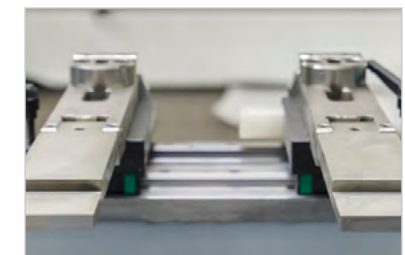

Practical: Integrated tool storage (optional)

Particularly practical: A tool storage area can be integrated into the side panel of the new GeniusPlus press brake, allowing the most important upper and lower tools to be quickly accessible whenever needed.

Sustainability & Efficiency: Electro-hydraulic press drive

The GeniusPlus series is equipped with an innovative electro-hydraulic system. The agile drive system in combination with the highly dynamic IRIS safety equipment from lazersafe® ensures, among other things, a performance increase of up to 35% compared to purely hydraulic press drives by a corresponding reduction in cycle time.





The Value of a Choice

Headquarters:

ACCURL Europe GmbH
Messerschmittstraße 10
D-86825 Bad Wörishofen
Germany

+49 8247 96294-50
sales@accurl-europe.com
www.accurl-europe.com

Showroom, R&D center:

Messerschmittstraße 3
D-86825 Bad Wörishofen



Fürst-Leopold-Allee 92
D-46284 Dorsten



Find the complete information from this
brochure and more online at
www.accurl-europe.com